

# Networked Electricity

February 26, 2019

Bruce Nordman

Lawrence Berkeley National Laboratory

[bnordman@lbl.gov](mailto:bnordman@lbl.gov) – [nordman.lbl.gov](http://nordman.lbl.gov)



Image from Eric Brewer talk  
**“Energy in the Developing World”**

January 14, 2010  
(LoCal Retreat)

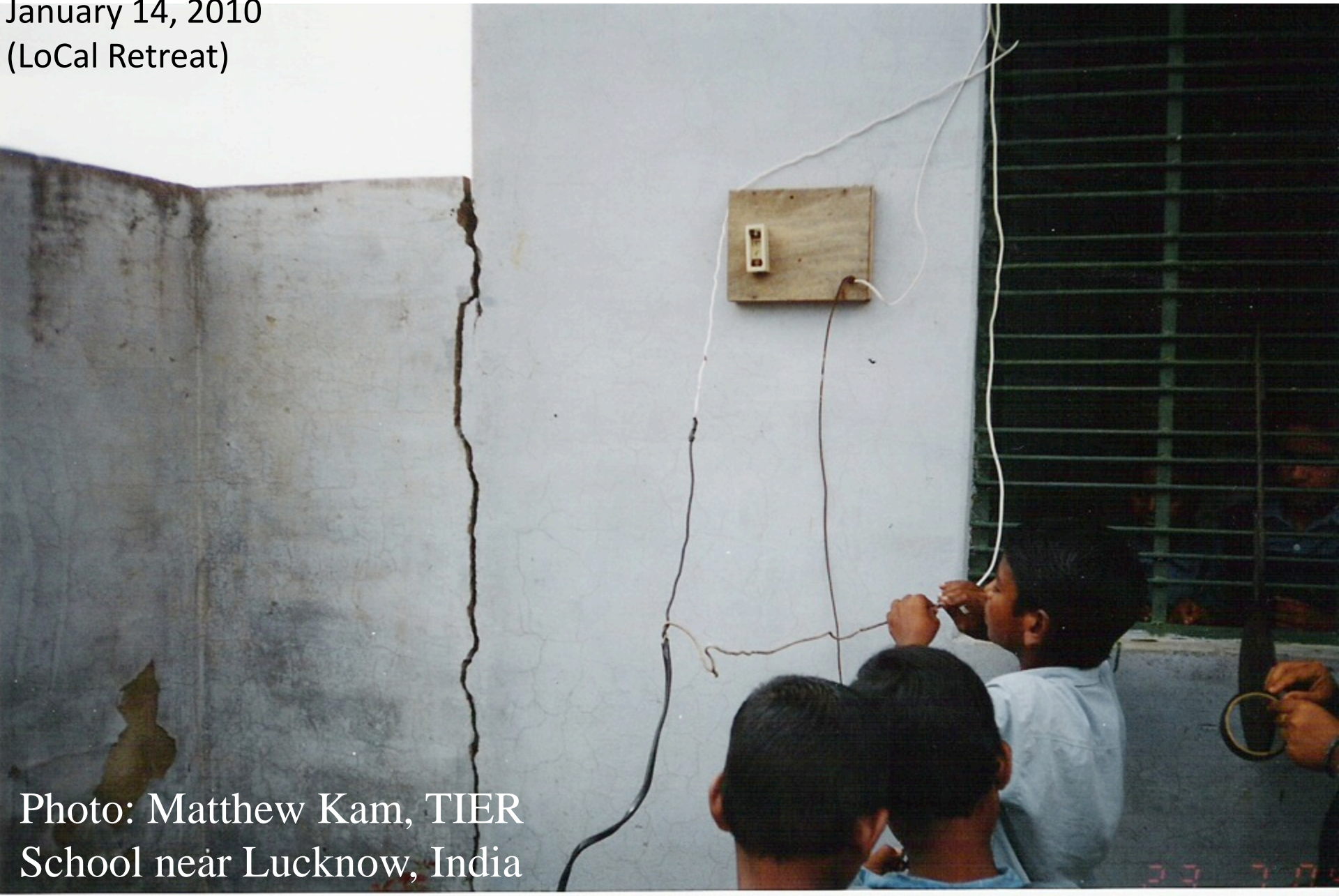

Photo: Matthew Kam, TIER  
School near Lucknow, India

# Features we should demand for Power Distribution

- “Plug-and-play” operation
  - End-use devices
  - Local generation
  - Local storage
- Improved safety
- Arbitrary power topologies – inter-building links
- Fine-grained management of constrained supply
  - Optimal use of distributed storage
- Greater reliability – and lesser
- Universal technologies
- Enabling optimal operation with a local price
- Security / privacy
- Greater efficiency with Direct DC

# “Local Power Distribution”

- “Local” – within a building (or campus)
  - Not involving utility grid
- “Power Distribution”
  - “Technology / infrastructure that moves electrons from devices where they are **available** to devices where they are **wanted**”

Local Power Distribution is a  
**network model of power**

# Grid terminology

- **Microgrid**

**Capability**

“... a group of interconnected loads and distributed energy resources ...that acts as a single controllable entity with respect to the grid. A microgrid can connect and disconnect from the grid to enable it to **operate in both grid-connected or island-mode.**” (*DOE Microgrid Exchange Group*)

*Implies must connect to utility grid; CIGRE C6-22 defn. similar*

- **Nanogrid**

**Simplicity**

“A **single domain of power**; single voltage, frequency (if AC), reliability, quality, capacity (power), **price**, and administration. Storage is internal to a nanogrid.” Generation forms its own nanogrid. (*Nordman, 2010*)

- **Picogrid**

**Singularity**

An **individual device with its own internal battery** for operation when external sources are not available or not preferred, and managed use of the battery. (*S. Ghai et al. in e-energy 2013; paraphrased*)

# Telephony - then

- My childhood phone\*



- Part of monolithic phone system
- Incapable of independent operation

# Telephony – one future

- Digitize the past



- Slightly better version of old technology
- Still can't do anything really new

# Promised telecom future

- Videophone - 1964 World's Fair (New York)



- Never happened
- Still point-to-point model



# Telephony - now

- Multiple fundamentally new technologies and paradigms



- Does many things impossible with old concept
- Highly useful even with no 'grid' connection
- Much more expensive than old telephony

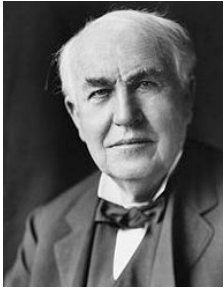

# 137 ... 888 years later

Generation

End use

Distribution

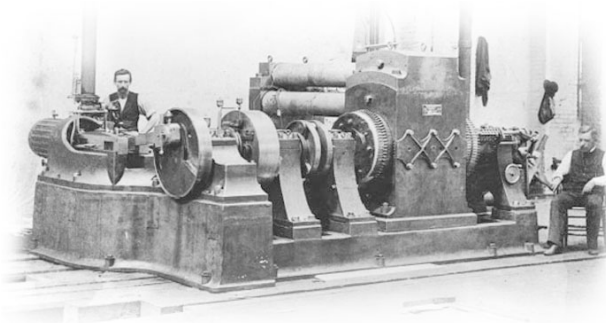

# Traditional power distribution

“Unitary grid” - single undifferentiated “pool” of power

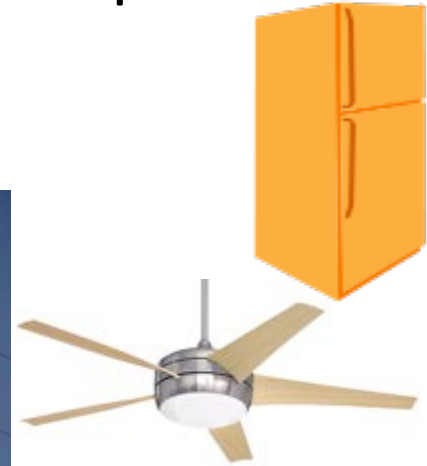
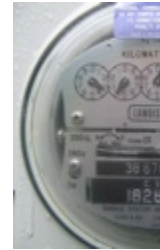

- Buildings and all devices part of the pool

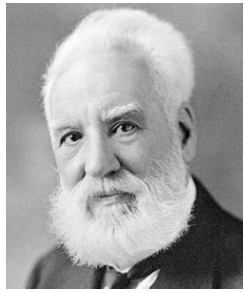

Bell

Edison

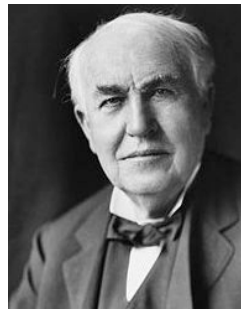

# Communications and Power

- Phone system and utility grid invented about same time (circa 1880)
  - Synchronous – highly coupled
  - Unitary – to end points – centrally managed
  - Organizations conservative - regulated
  - Technology advances slowly
  - Local variations in technology - minor
  - One mode of operation

# Paradigms

*Unitary*

*Networked*

**Old phone system**

**Internet**

**Utility grid**

**Network model of power**

19<sup>th</sup> century

20<sup>th</sup>/21<sup>st</sup> century

Centralized

Distributed

Analog

Digital

No storage

Storage widespread

Tightly coupled

Loosely coupled

Entangled technology

Isolated technologies

Custom / Expensive

Commodity / Cheap

.....

.....

*Need paradigm shift*

# Power & information distribution

“Technology / infrastructure that moves data / electrons from devices where they are available to devices where they are wanted”

*All bits (packets) different; all electrons same*

- Need a **fundamental mechanism** for a network model
- Communications: understand system topology (addressing) and move data accordingly
  - Data routing is how bits know where to go
- Power: balance supply and demand
  - Price is how electrons know where to go
    - Routing power makes no sense

**Location, quantity, timing**

# Paradigm changes

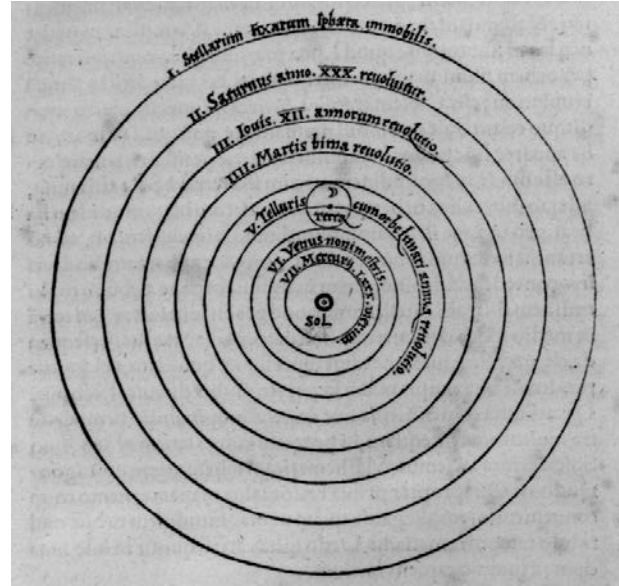

# Indications for network model of power

- Use digital technology everywhere
- Use storage to decouple/desynchronize
  - Distribute widely for stability, reliability
- Diverge technology in buildings from backbone technology
- Derive inspiration from electronics/IT — not from utility grid
- SIMPLICITY — complexity



# Layered models – (e.g. OSI Model)

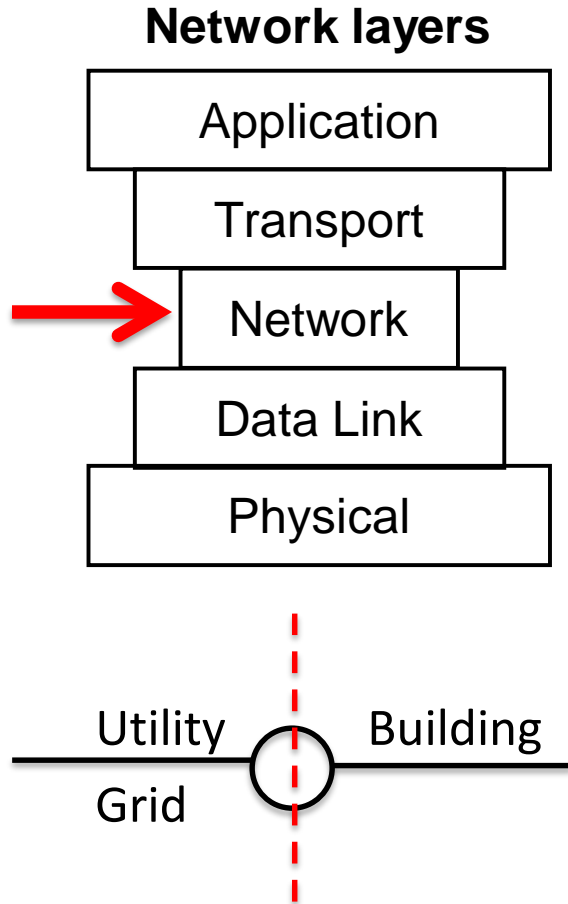

- Narrow waist in layering **isolates complexity** – facilitates interoperability
  - Buildings need three layered models
- Conventional network communication
  - Application and physical layers
- Electricity / utility meter
  - Utility grid from building
- Device internal Network Power Integration
  - Power distribution distinct from functional control

- Prices down; meter readings up
- Electrons either direction

# Layered model for device operation for Local Power Distribution

---

## Network Power Integration

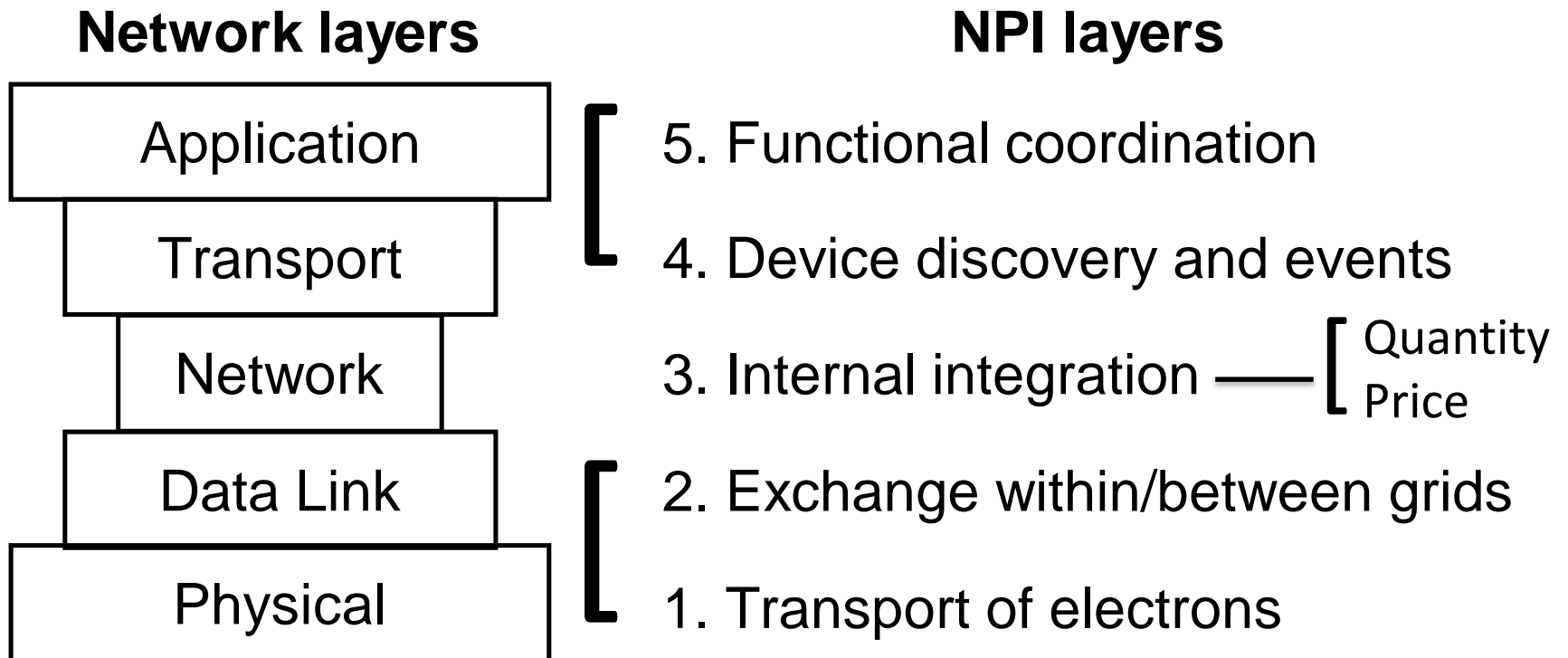

# Scaling structure — communications and power

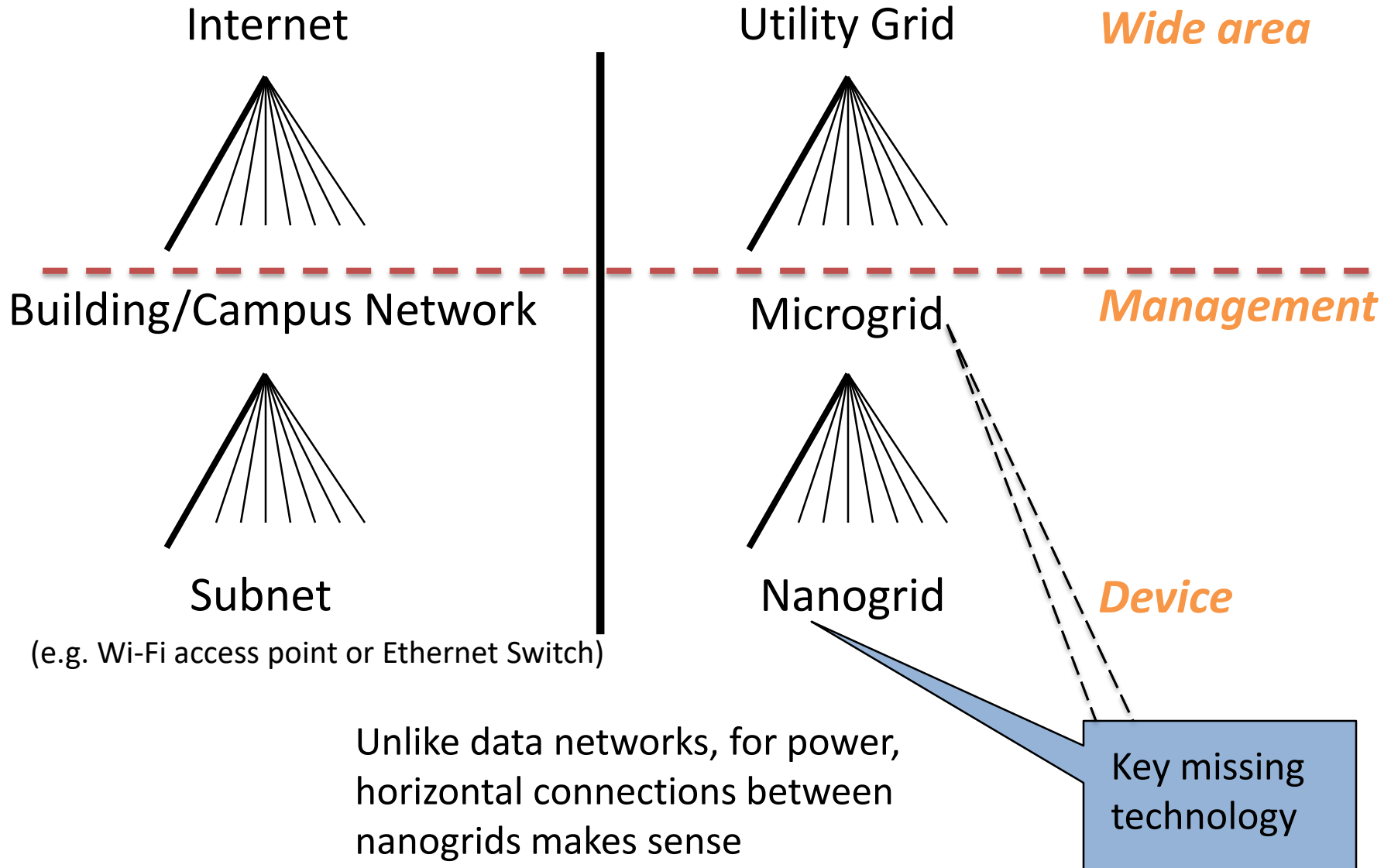

# What is a Nanogrid?

- Smallest unit of power distribution
- Single physical layer (voltage; usually DC)
- Single domain: administration, reliability, capacity, and **price**
- Can interoperate with other local grids
  - Generation forms own nanogrid
  - Only two device types: grid controller and load
- In fully-functioning nanogrid, all links include communications
- Wide range in technology, capability, capacity

Gateways to other controllers (nG or  $\mu$ G) or local generation

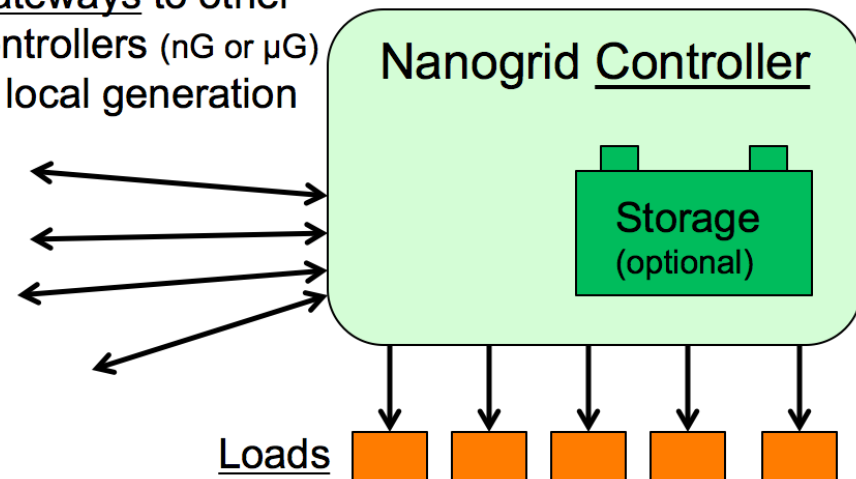

# Example local grid network

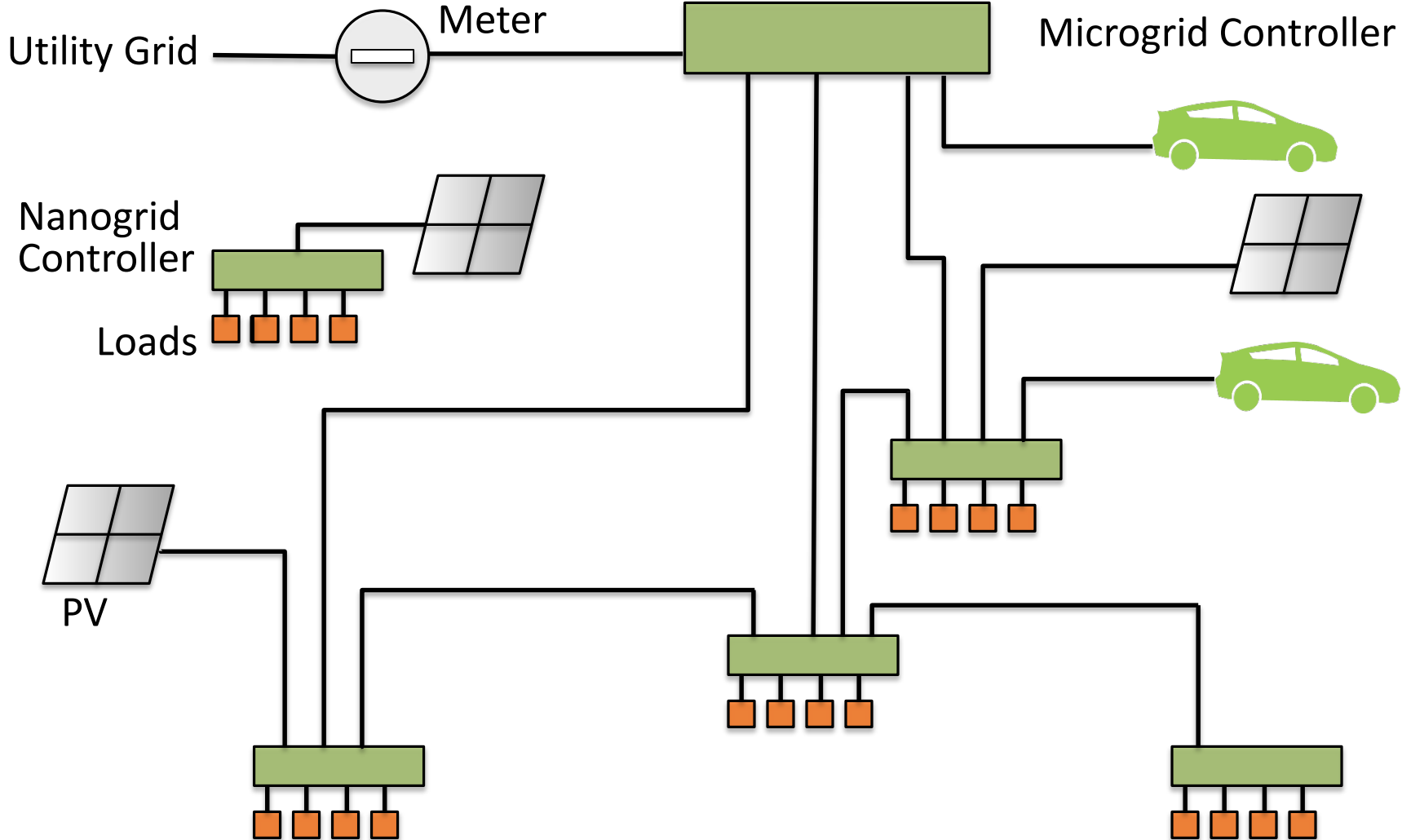

*All connections peer-to-peer and can be changed dynamically  
Price is how devices know which way power should flow*

# Example local grid network

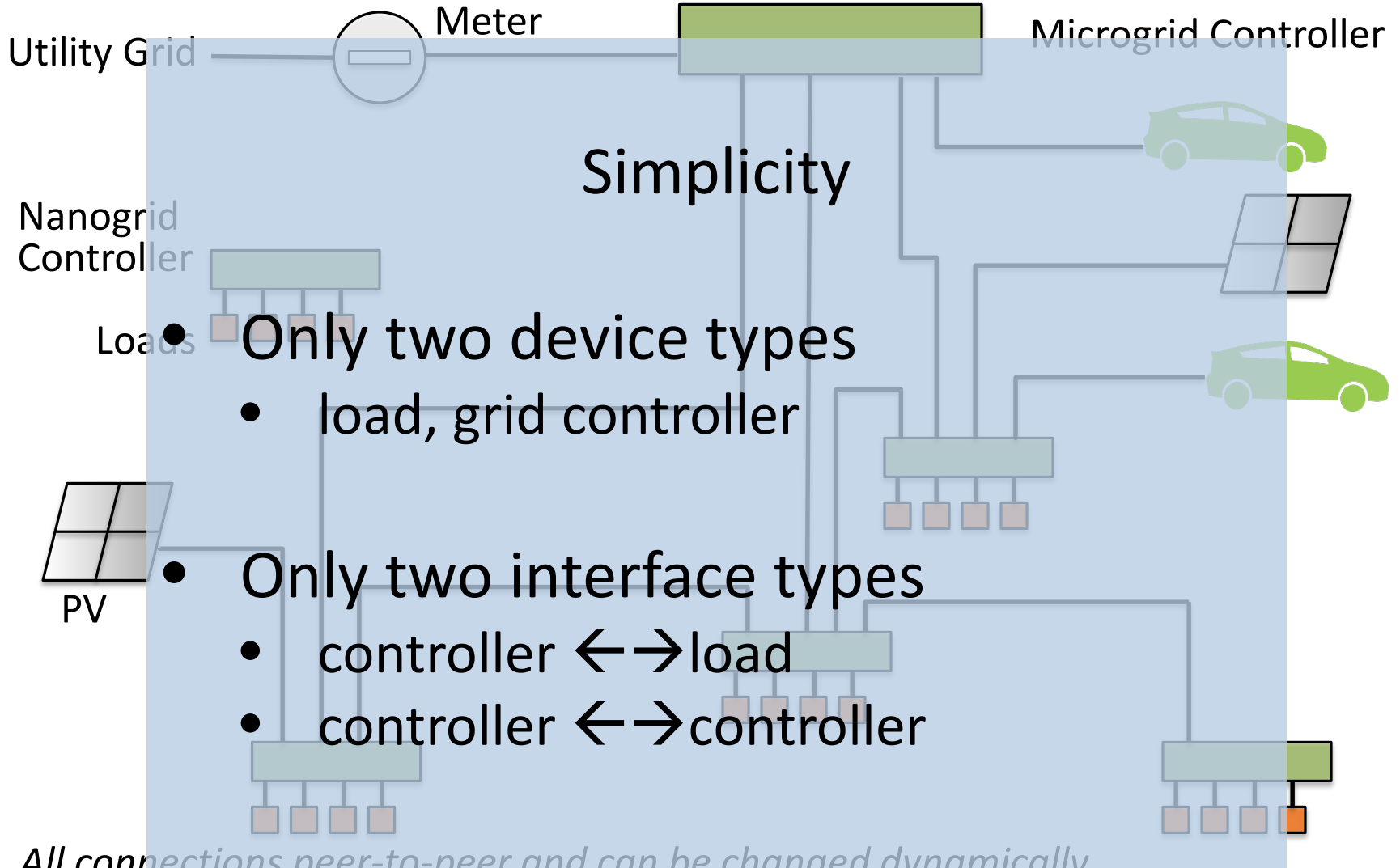

*All connections peer-to-peer and can be changed dynamically  
Price is how devices know which way power should flow*

# Features we should demand for power distribution

- “Plug-and-play” operation
  - End-use devices
  - Local generation
  - Local storage
- Improved safety
- Arbitrary power topologies – inter-building links
- Fine-grained management of constrained supply
  - Optimal use of distributed storage
- Greater reliability – and lesser
- Universal technologies
- Enabling optimal operation with a local price
- Security / privacy
- Greater efficiency with Direct DC

LPD provides these features

# Myth of uniform power availability

- Electricity is not equally available across space and time
  - Has long been true within utility grid
    - “Locational Marginal Price”
  - Increasingly true within buildings
    - Local storage and/or generation, islanded grids, capacity constraints, combined heat-and-power, vehicles/mobile
- Technology we have today presumes uniform availability – **hence constant price**
- Dynamic pricing at meter a needed starting point
  - Grid can express preferences to customer





# Reasons for differing local prices

- Differential buy/sell prices from utility
- Local valuation of carbon
- Losses from AC/DC or voltage conversion, battery losses, wiring losses
- Capacity constraints
- Off-grid operation – incl. mobile
- Battery management goals
- Local generation conditions (dispatch; co-gen)



Price always **current** price and a  
non-binding **forecast** of future prices

# Communication about power

## “Standard DC”

A method for transmitting DC power defined by a well-known technology standard, enabling plug-and-play interoperability

## “Managed DC”

Standard DC technologies that include communications for managing power distribution within the power cable & connector

- Communications over power wires or adjacent wires
- Examples: PoE and USB

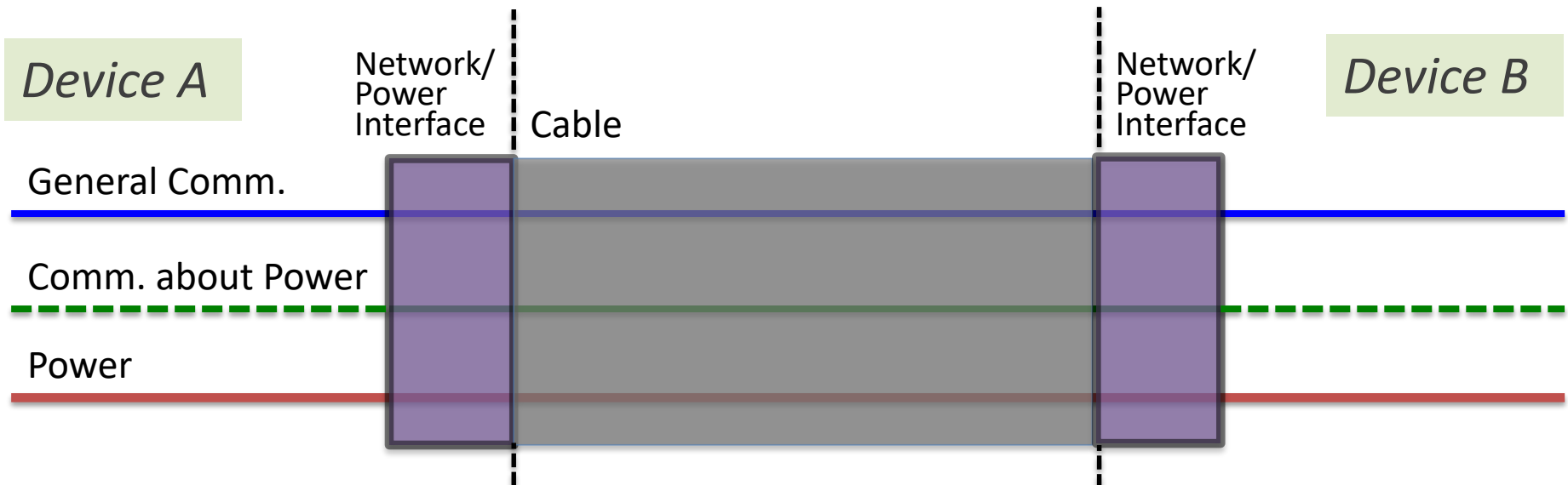

# Link Technology for LPD

- USB and Ethernet have
  - Communications about power
  - 100 W per cable (HDBaseT; Ethernet 90W)
  - Bidirectional power (HDBaseT)
  - Power ‘hubs’ with integral storage
- USB and Ethernet need
  - Local price\*
  - Controller-controller coord.
- Need to consider for each
  - Multi-drop capability

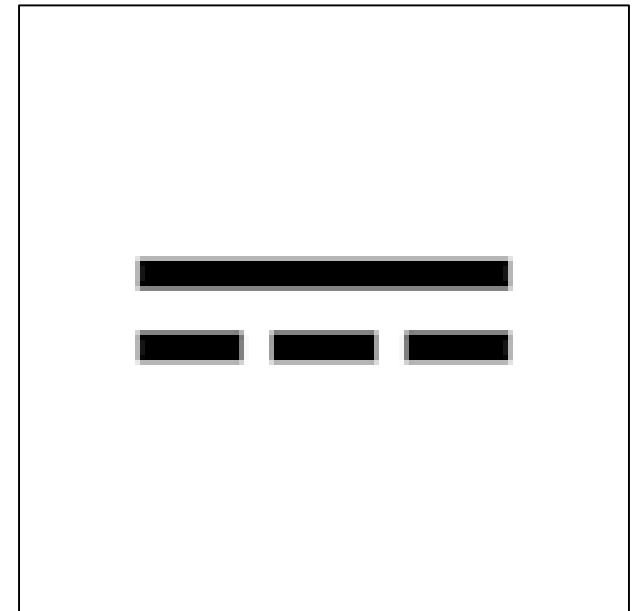

*\*Ethernet now has*

# Example: Price-responsive light

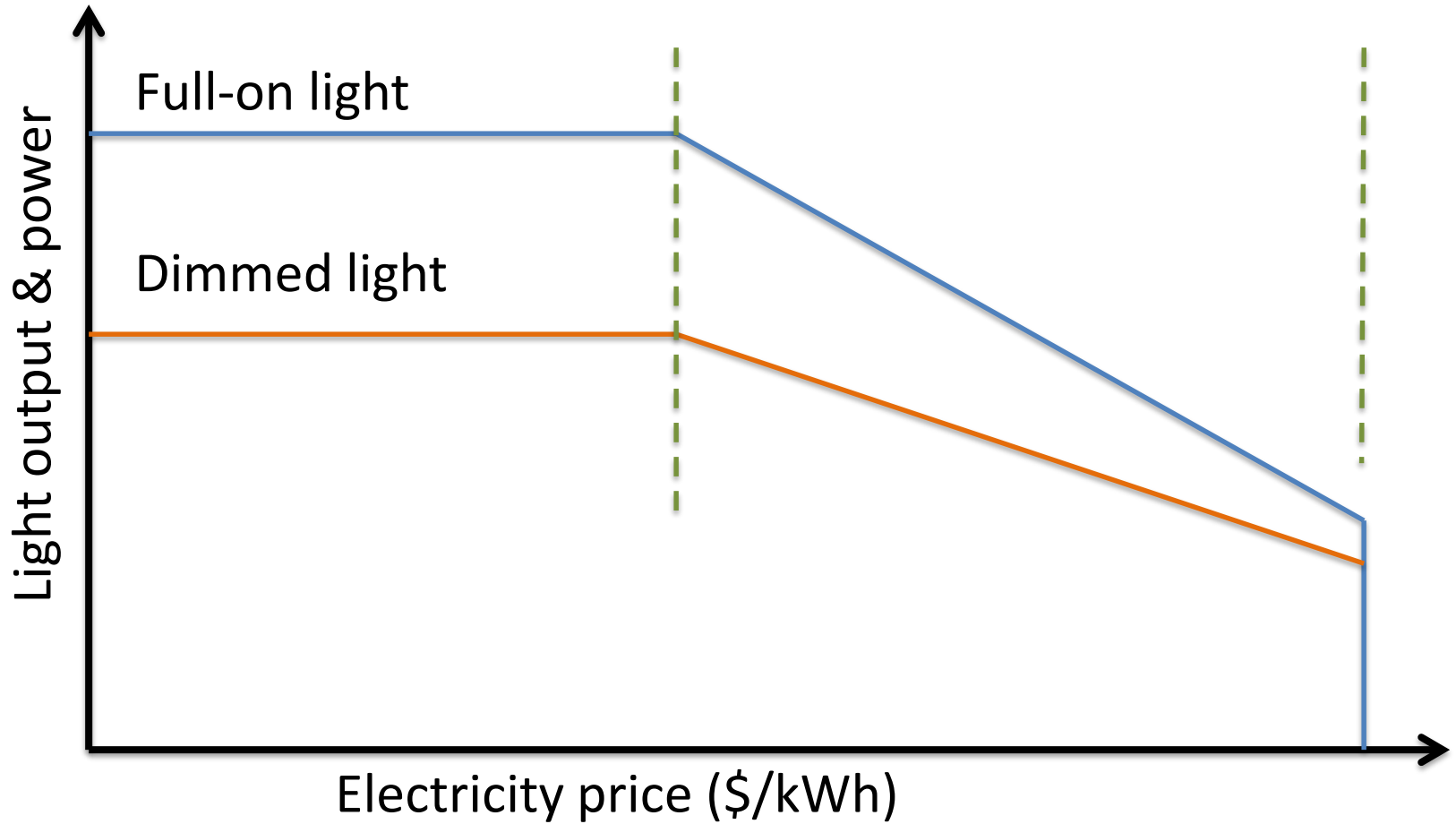

Control algorithms can change at any time

# Example: Price-responsive freezer

- Off-grid context
  - Source, storage, end use
- Operation
  - PV → Price → Setpoint → Compressor

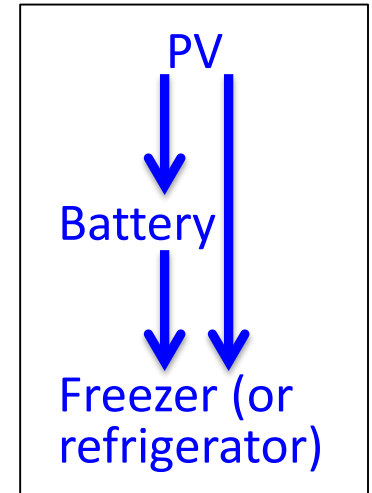

- Variable price created as inverse of PV output

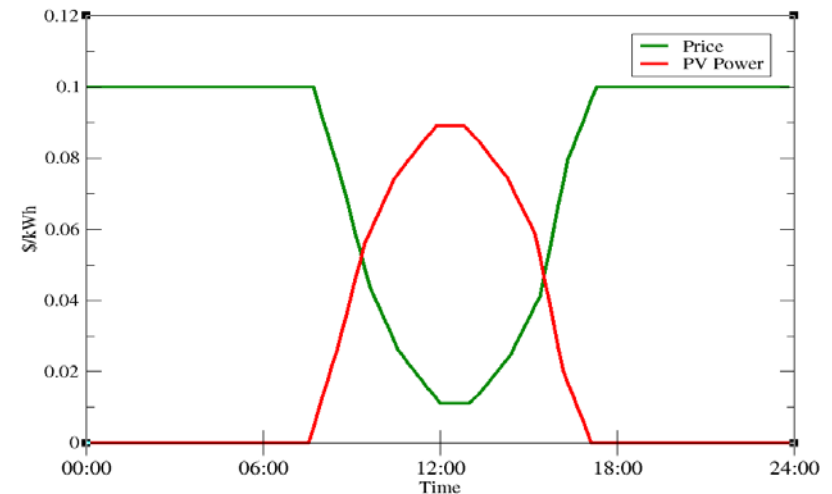

# Freezer — Constant price

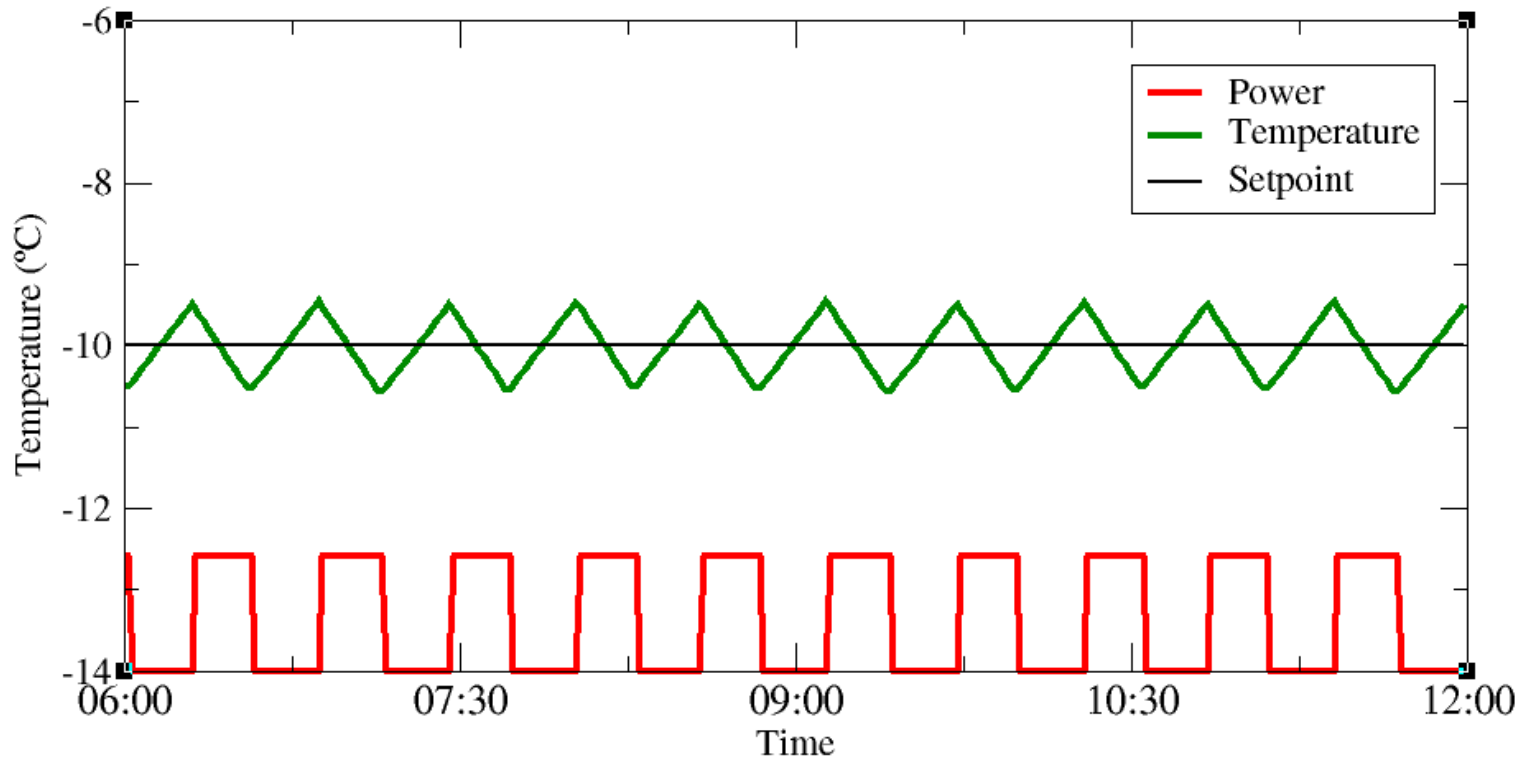

- Constant setpoint (-10 C)
- Compressor on-times and off-times about 20 minutes each
- Behavior never varies

# Freezer — Variable price (6 hours)

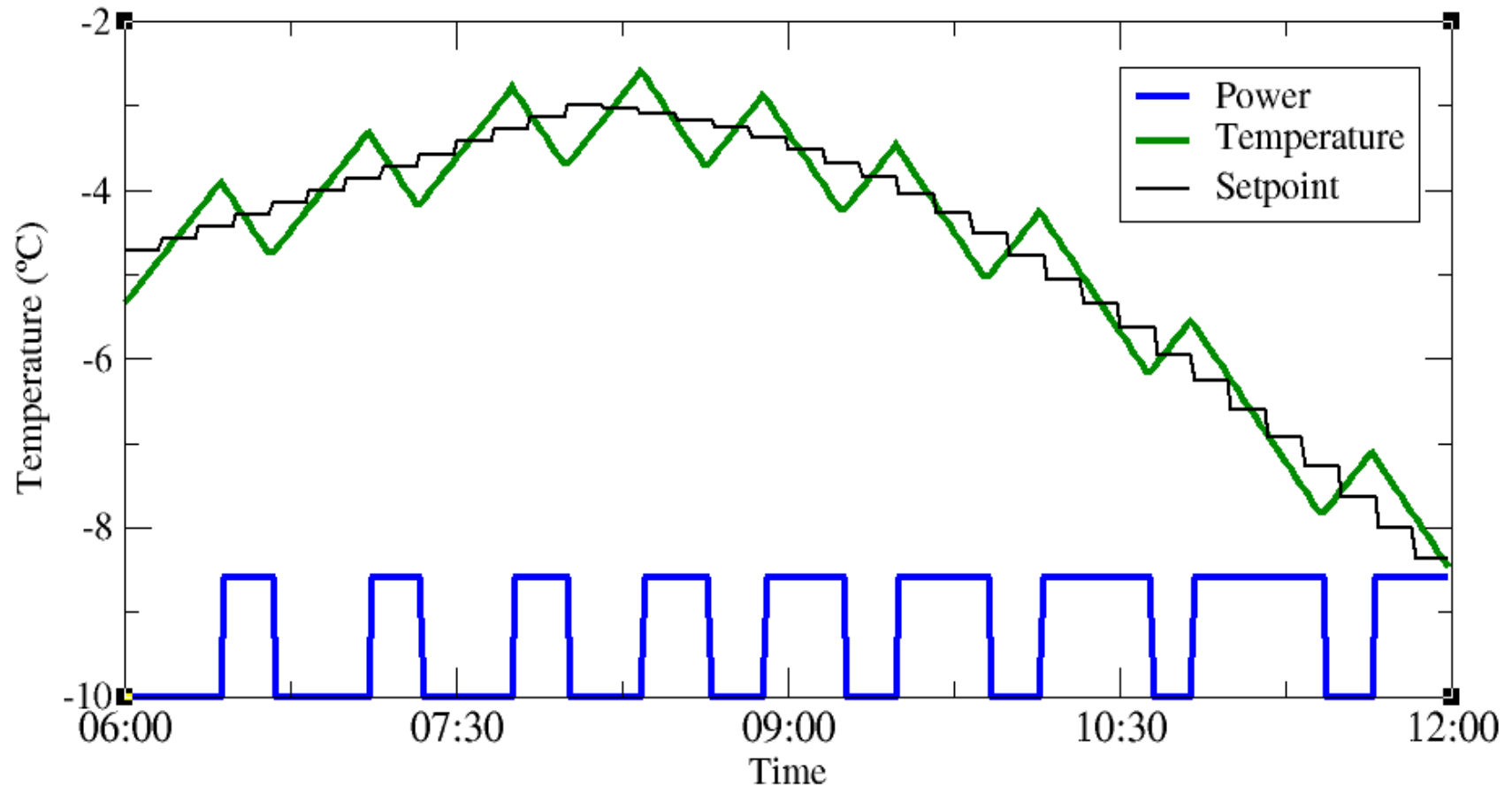

- Variable Setpoint (-3 C to -18 C )
- Variable compressor on-times and off-times
  - (10 minute minimum on-times)

# Freezer — Variable price (24 hours)

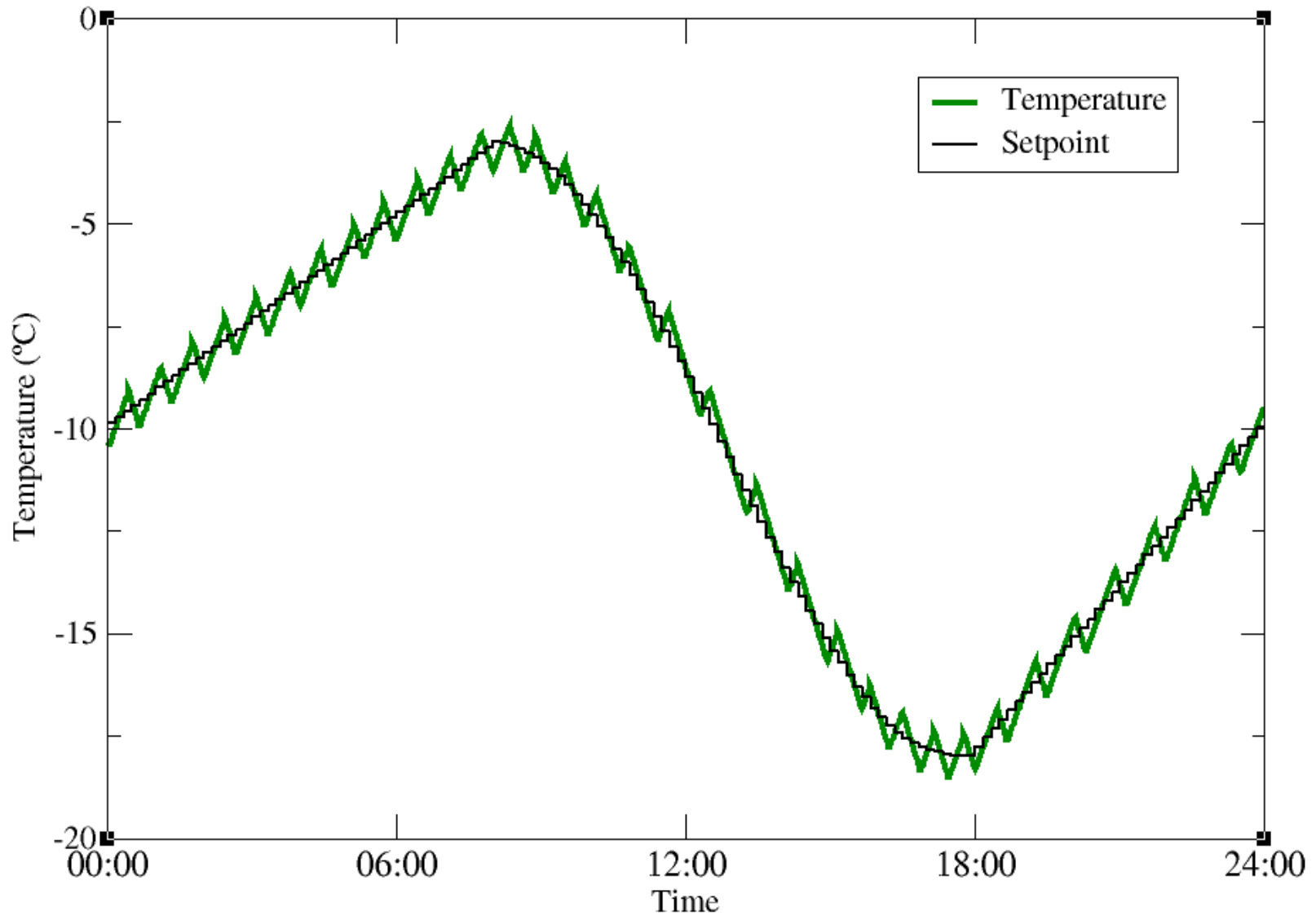



# Freezer energy use

(average power per cycle)

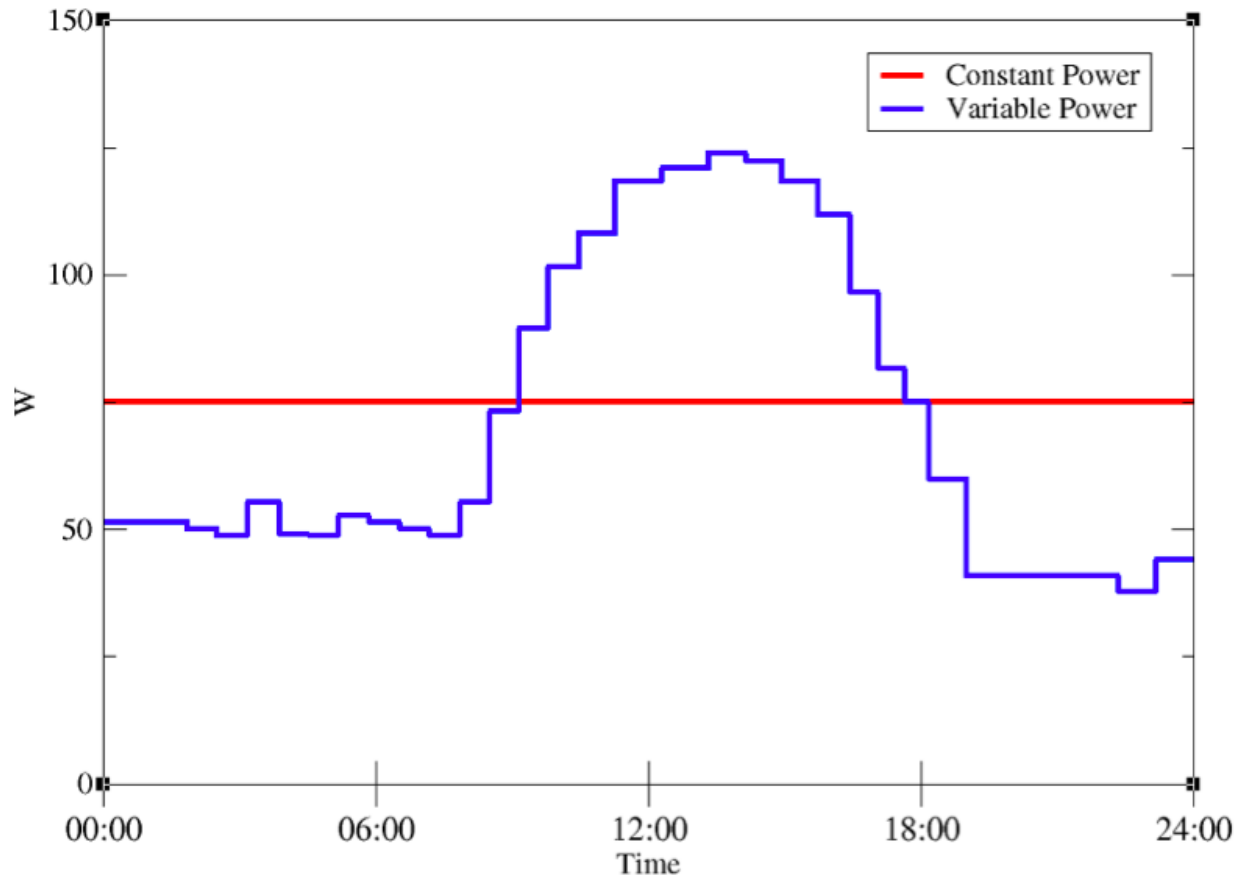

- Less energy used overall (More direct DC)
- Smaller battery
- Less PV
- Lower battery losses

# Simulation Results - more devices

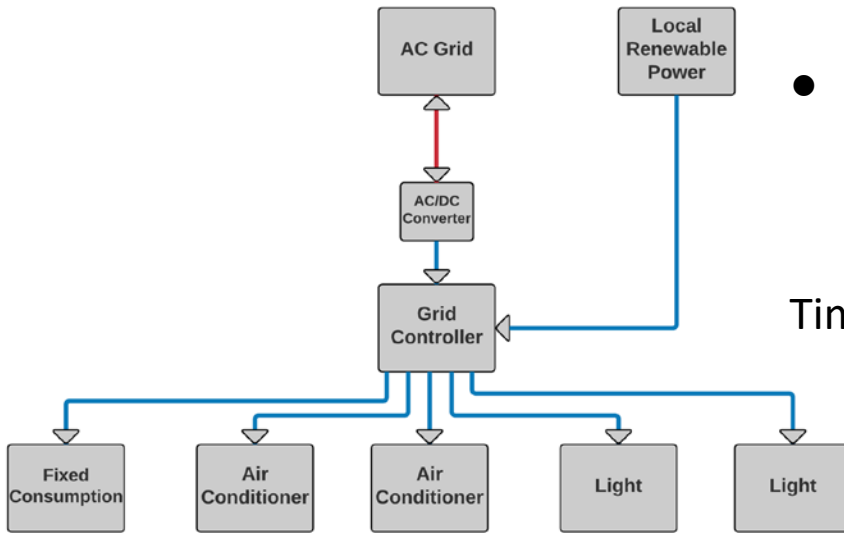

- Price at meter – 3 scenarios
  - Flat
  - TOU – net metering
  - TOU – self supply

Time-of-Use

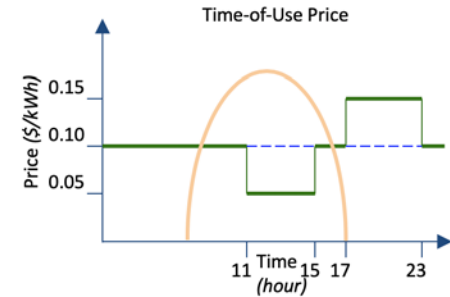

Total - All Scenarios

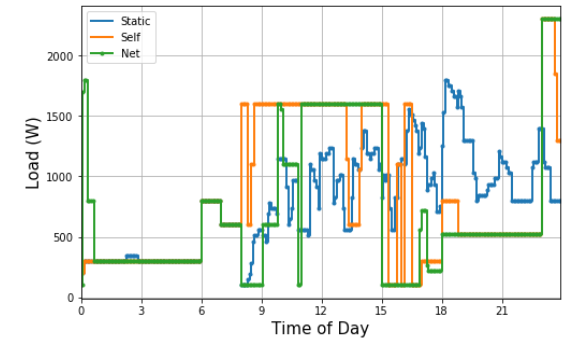

- Storage - air conditioner and battery - shift load
- Lighting - dims
- Prices effective at shifting load to low-price times
- Net metering most effective at reducing energy and costs
- Self-supply uses more energy but reduces costs

	Static	Self Supply	Net Metering
Energy (kWh)			
Low - \$0.05/kWh	-2.35	0.16	1.16
Medium - \$0.10/kWh	4.23	7.35	3.89
High - \$0.15/kWh	6.7	2.23	2.03
<b>Total</b>	<b>8.58</b>	<b>9.74</b>	<b>7.09</b>
Cost (\$)			
Low - \$0.05/kWh	-0.12	0.01	0.06
Medium - \$0.10/kWh	0.42	0.73	0.39
High - \$0.15/kWh	1.01	0.33	0.31
<b>Total</b>	<b>1.31</b>	<b>1.08</b>	<b>0.75</b>
<b>Total - Export \$0.00</b>	<b>1.56</b>	<b>1.11</b>	<b>0.98</b>

“Total” cost - export paid at purchase rate

“Export \$0.00” - export to the grid paid nothing

# Communications Details

*No fixed time-steps; No central clock; No central entity*

*Any message can be sent any time*

## Price

- **Price:** GC sends a price (incl. forecast) any time it changes ( $\$/kWh$ )

EUD: End-Use Device  
GC: Grid Controller

## GC <--> EUD (1-way power flow)

### Power Allocation

- **Request:** EUD requests authority to consume up to  $XX\ W$
- **Allocate\*:** GC grants the EUD
  - full power request or partial grant or no power at all
  - *EUD may then consume any amount of power between zero and the granted amount*

## GC <--> GC (2-way power flow)

*Prices establish direction of any power flow (low to high)*

### Power Allocation

- **Allocate:** Each GC announces to the other how much power is available
  - *The lower power level is set for the exchange quantity*
  - *Power flows across the link*

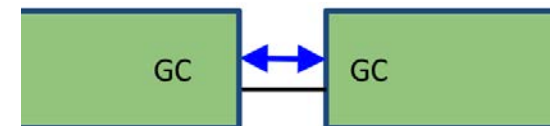
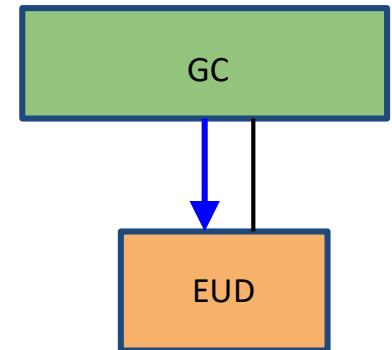

# Proposed deployment path

- Use DC as integrator of local generation, local storage, vehicles, reliability
  - Storage integral to nG controller
  - Enables “Direct DC”
- Enable modest reliable AC
  - e.g. refrigerator
- Amount of power exchanged between DC, AC small
  - Most DC power stays in DC domain
- Can add DC capability incrementally and organically
- Can exchange power with neighboring buildings
  - Useful in disaster scenarios

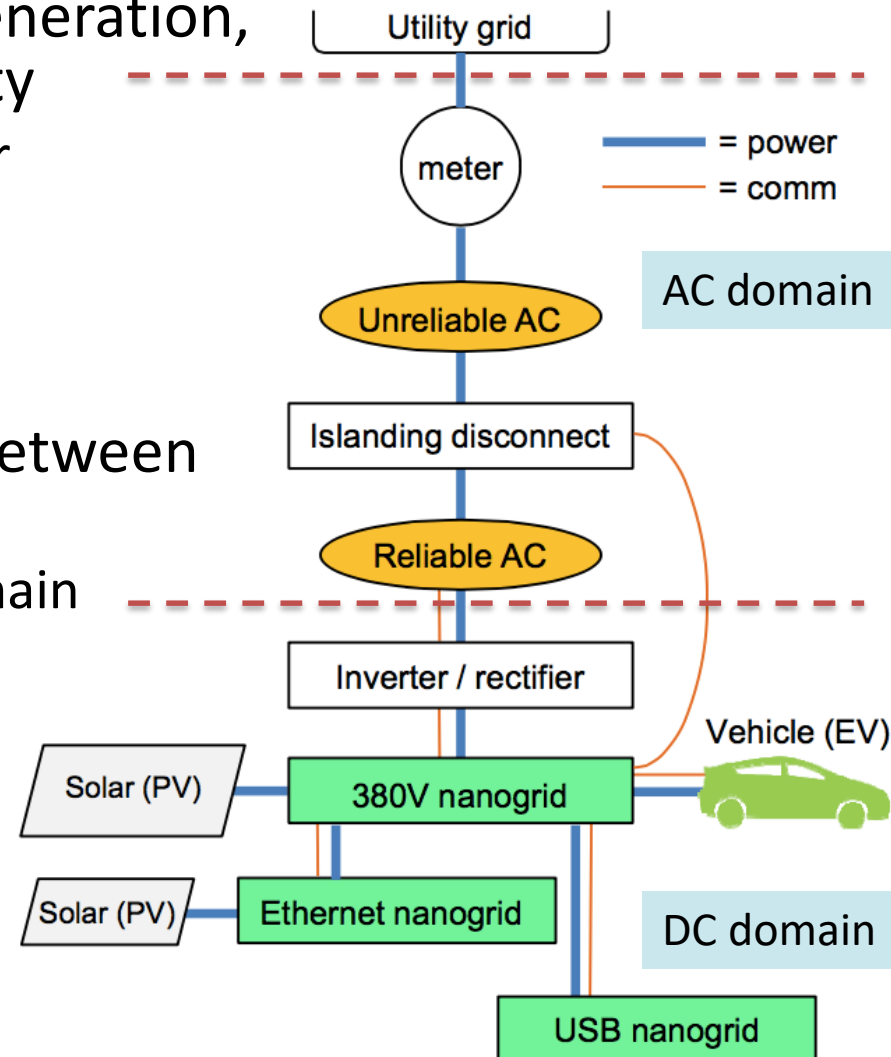

# Reliable Communications



## *Issue*

- Communications (VOIP, Internet) no longer reliable during grid outages
- AC UPS are expensive, inefficient, non-optimized



## *Solution*

- All communication devices be USB-powered
- Consumers have USB hub with integral battery
- Battery provides reliable power for many hours
- Hub can signal when on battery
  - Devices can reduce services to save power
- Could connect PV panel for multi-day reliability
  - Buy solar one panel at a time
  - No permits, no prof. labor – plug-and-play
- Can take camping



# Summary

- Need network model of power
  - LPD is one – highly practical
- Nanogrids can be key to success of microgrids
  - Can be deployed faster, cheaper
- Essential technologies
  - Pricing
  - Bi-directional power
  - Higher capacity links
- Keep traditional grid, but make it *less* reliable
- Nanogrids are a “generally useful technology”

Thank you

